

Name: \_\_\_\_\_

Date: \_\_\_\_\_

**Aim 24:** What are the layers of the Earth?

Read the following about the layers of the Earth and answer the questions that follow:

### Journey to the Center of the Earth: Reading Comprehension

We all call the Earth home, but did you ever think about what our home is actually made of? The planet is approximately 6,400 km from surface to center, but what makes up those kilometers of Earth? If we could travel through the layers of the Earth, what would our trip be like? In order to make this trip, we would need a special vehicle that could travel through both liquid and solid rock and that could withstand intense temperature and pressure changes! The deeper into the center of the Earth the hotter and it is and the more pressure we will face.

In 1961 scientists drilled a hole 200 m into the oceanic crust. They hoped to reach the Moho Discontinuity. Unfortunately, the project was canceled after Phase I. At this time, we still do not have the technology needed to make it through the entire rocky layer of Earth, let alone into deeper layers.

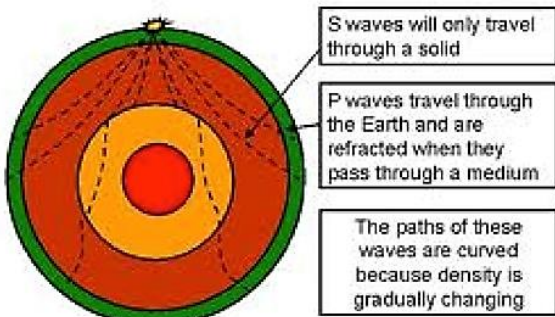
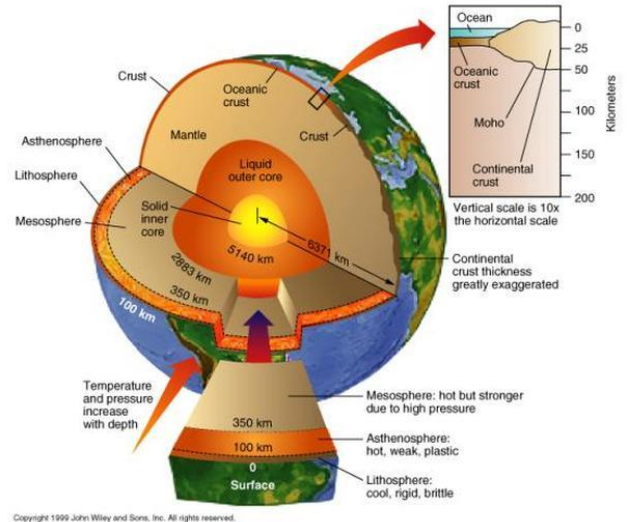

Observations: 1) It has a thin crust, 2) it has a semi-fluid mantle where density increases with depth, 3) a core with a liquid outer part and a solid inner part

So how do scientists study Earth's interior if we can't get to through it? Seismologists are geologists who study seismic waves to learn about Earth. Studying the behavior of earthquake waves to gather data about Earth's interior is similar to using sound waves to see inside the human body. Observing seismic waves allows scientist to infer images of Earth's interior. Data has shown that seismic waves bend when they encounter sharp changes in density. There are different kinds of seismic waves, known as P- waves (which can travel through liquids and solids) and S-waves (which can only travel through solids). Studying these waves help seismologists theorize the composition, thickness, density, and phase of the four layers of the Earth.

Let's start our journey to the center of the Earth! In order to make it through, we have to start with the part of the Earth that we live on, the outermost rocky layer called the **crust**. This layer can range from 5 to 40 kilometers thick, the thickest sections occurring at mountain ranges and the thinnest sections part of the ocean floor. The crust is separated into two parts- **Oceanic crust** (ocean floor) which consists mostly of dense rock such as basalt and **Continental Crust** (dry land) which consists mostly of lighter and less dense rock such as granite.

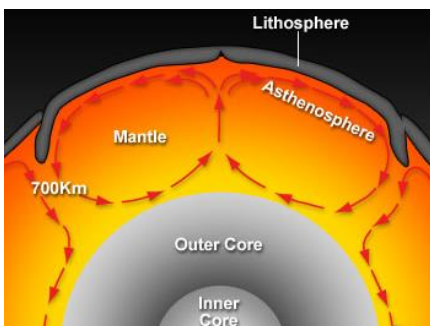
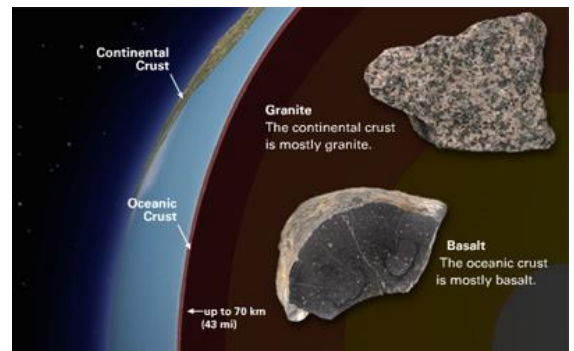

We come to a boundary. Above this boundary the rocks of the crust, below a layer of the hot rocks of the mantle. Together these form a rigid, rocky layer of Earth known as the **Lithosphere**, which averages about 100 km thick. We continue into the mantle, where our vehicle encounters a hotter, softer material that is under increasing pressure. This must be the **Asthenosphere**- the soft, hot, plastic-like layer of the Earth that is constantly flowing slowly by convection

currents. Pieces of the lithosphere float on top of the asthenosphere and another solid layer of material lies below, making the mantle nearly 3,000 km thick.

Finally, we've made it to the core! Phew, it's SO hot down here! There are two parts of the nearly 3,500 km thick core- a liquid outer core and a solid inner core. The iron and nickel material in both layers of the core make up about 1/3 of Earth's mass, but only about 15% of its volume. The core is just slightly smaller than the moon. The molten metal outer core flows like a thick liquid, but there is so much pressure on the atoms of the inner core that they are pressed together into a dense ball of solid metal. We should probably get out of here, before the enormous pressure and 5,000°C temperature turn our vehicle into a solid ball too!

**Questions:**

1. Complete the chart below based on the information from "Journey to the Center of the Earth."

	Crust	Mantle	Outer Core	Inner Core
Composition	Oxygen, Silicon, Aluminum, Calcium, Iron, Sodium, Magnesium, Potassium	Silicon, Oxygen, Iron, Magnesium		
Thickness/Depth				
State of Matter (S, L, G)				

2. What happens to the temperature as we traveled closer to the center of the Earth?
3. What happens to the pressure as we traveled down?
4. What rocks make up most of the Earth's crust?
  - a. Oceanic-\_\_\_\_\_
  - b. Continental-\_\_\_\_\_
5. Why do you think the ocean crust contains rocks that are more dense than the rocks found on land?
6. What makes up the lithosphere?
7. The plates of the lithosphere move slowly because they float on top of the asthenosphere. Describe how the molten material in the mantle causes this movement of the lithospheric plates.

1. Label the following layers of the Earth on each figure below: **Inner Core** **Outer Core** **Mantle** **Oceanic Crust** **Continental Crust**
2. Add the following labels to Figure B only: **Lithosphere** **Asthenosphere** **Convection Currents** **Mantle layers (Upper, Middle, and lower)**
3. Color the following layers. Make sure that the matching layers in each picture are the same color. Fill in the Color Key below.

Color Key: Inner core  Outer Core  Lithosphere  Asthenosphere  Oceanic Crust  Continental Crust

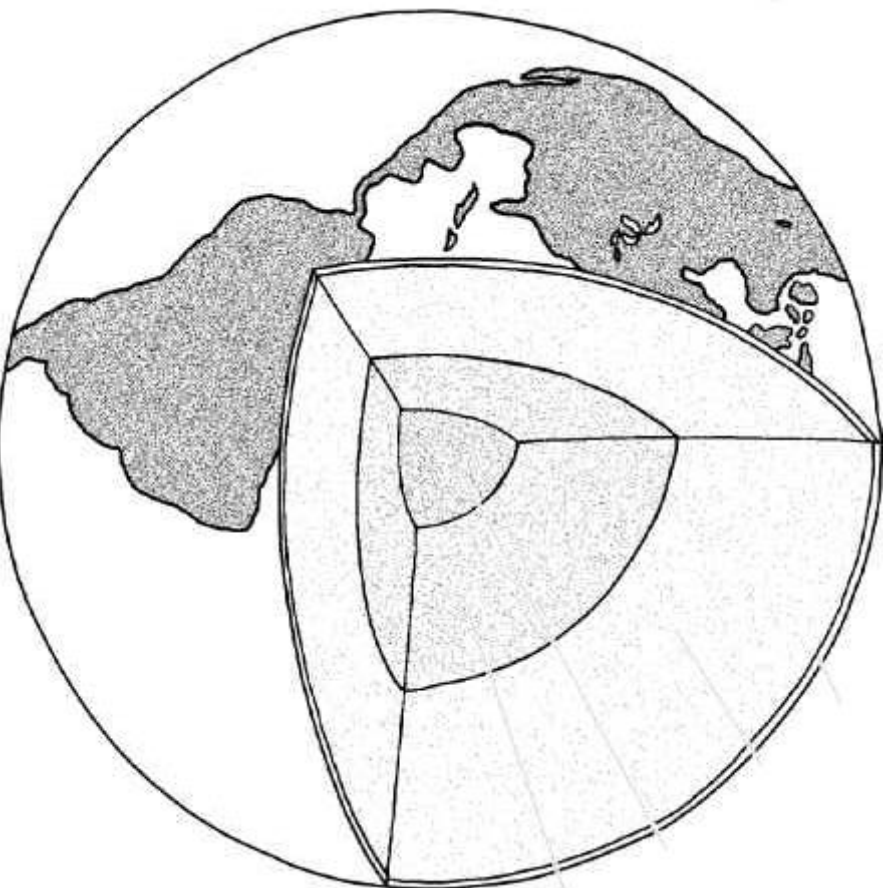

Figure A

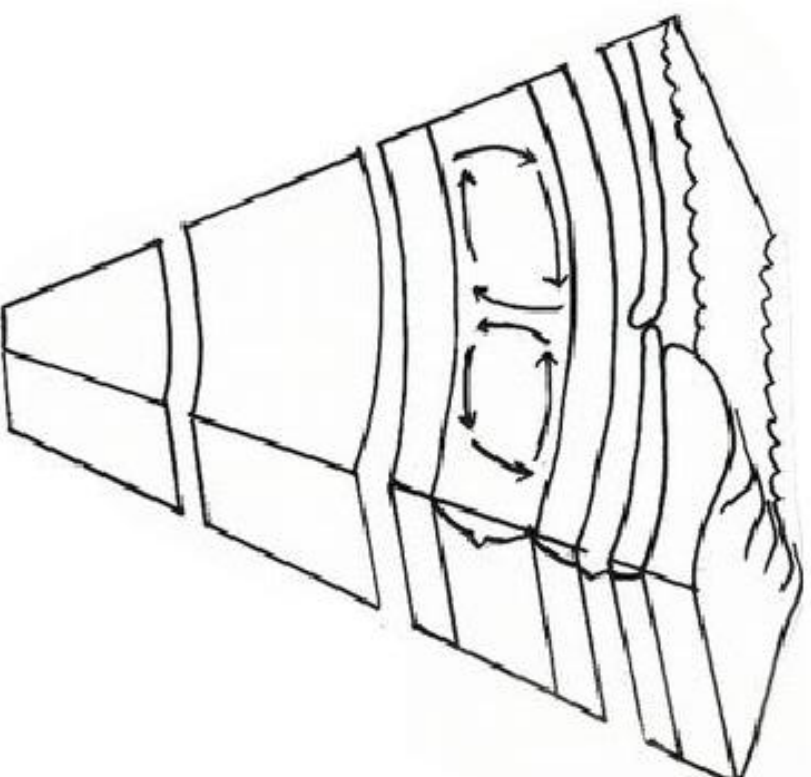

Figure B